

Laser-Stimulated Chemical Reaction of  $I_2 + C_2H_2$ Vikram S. Kushawaha<sup>†</sup>*Contribution from the Ames Laboratory, U.S. Department of Energy,  
Iowa State University, Ames, Iowa 50011. Received June 12, 1979*

**Abstract:** The laser-initiated chemical reaction of  $I_2 + C_2H_2$  has been studied by exciting the B-X system of the  $I_2$  molecule at 4880, 5145, and 6040 Å, using the output from an  $Ar^+$  laser and a CW dye laser pumped by an  $Ar^+$  laser. At 5145 and 4880 Å, the reaction products were mostly  $C_2H_2I_2$  and a trace amount of  $C_2H_2I_4$ , which was greater at 4880 Å than at 5145 Å and satisfactorily correlated with the excited iodine atoms produced at these wavelengths;  $C_2H_2I_2$  was the only product at 6040 Å. A mechanism for the reaction of the laser-excited  $I_2$  with the  $C_2H_2$  has been proposed and, on the basis of thermal experiments, has been indicated to be nonthermal.

## Introduction

Lasers, a highly monochromatic light source, are recognized as a very powerful tool for selective isotope separation of rare elements, chemical reactions, and isomerization of molecular species.<sup>1,2</sup> In the recent past, there have been a number of contributions in this area of research using infrared lasers, mainly the  $CO_2$  laser,<sup>2</sup> by exciting the molecules from their ground-state vibrational level. Application of visible lasers to initiate chemical reactions of the electronically excited species with other molecules has been comparatively limited. Zare and co-workers<sup>3</sup> were the first to use these lasers in a chemical reaction and isotope separation of chlorine by electronically exciting  $ICl$  molecules in the mixture of  $ICl +$  olefins. Stuke et al.<sup>4</sup> and Harris<sup>5</sup> have also studied the laser-induced chemical reaction of the electronically excited  $ICl$  molecules with  $C_2H_2$  and  $H_2$ , respectively, as reaction partners. Letokhov et al.<sup>6</sup> have reported a separation of ortho-para modifications of  $I_2$  molecules by selectively exciting them in the presence of 2-hexene using the output from an  $Ar^+$  laser. Recently, we have studied<sup>7</sup> the formation of cis and trans isomers of 1,2-dibromoethylene in a chemical reaction of  $Br_2 + C_2H_2$  by electronically exciting the  $Br_2$  molecules in the B-X system at 4880 and 5145 Å.

In this communication, we wish to report the experimental methods used and the results obtained at 4880, 5145, and 6040  $\pm 2$  Å in a chemical reaction of  $I_2 + C_2H_2$  by exciting the B-X system of  $I_2$  molecule using output from an  $Ar^+$  laser and a dye laser pumped by an  $Ar^+$  laser. The purpose of this study was to search for a suitable scavenger molecule for a selective laser isotope separation of  $^{129}I_2$ , which is of industrial importance.<sup>8</sup> Letokhov et al.<sup>6</sup> have reported a scheme for separating this isotope which involves excited iodine atoms and therefore isotopic selectivity may not be preserved (see the Discussion). Also, the reaction kinetics do not seem to be very convincing. A suitable system for this purpose would be one which has no dark reaction, at least for a period of excitation, but does have a very high probability of reaction with the excited species and the wavelengths used do not produce atoms. The molecule  $C_2H_2$  and the wavelength 6040  $\pm 2$  Å for the excitation of  $I_2$  molecules fulfill all the requirements and seem to be a good choice for a selective laser isotope separation of  $^{129}I_2$ . A detailed kinetic study of  $I_2 + C_2H_2$  at 6040  $\pm 2$  Å will be described below. The choice of this wavelength among others is based on the fact that there is no atom production at this wavelength,<sup>9</sup> the probability of  $I_2$  excitation is good, and the rhodamine-6G pumped by an  $Ar^+$  laser has a very good output power.

## Experimental Section

The experimental details for the study of  $I_2 + C_2H_2$  at 4880 and 5145 Å are similar to those of  $Br_2 + C_2H_2$  and are fully described elsewhere.<sup>7</sup> Briefly, an identical mixture of  $I_2$  and  $C_2H_2$  was irradiated in a reaction cell (5.0 cm long, 2.5 cm internal diameter) using the laser lines at 4880, 5145, and 6040  $\pm 2$  Å for a fixed period of time. The photoproduct analysis was done by infrared (Beckman-210), GC-MS (Finnigan-420), and a gas chromatograph (Tracor-550, equipped with electron capture detector, Ni-63). This communication describes only the details of the experimental arrangement used in the kinetic study of  $I_2 + C_2H_2$  at 6040  $\pm 2$  Å.

The experimental setup used in this study is shown in Figure 1. The reaction cell was fabricated from a Pyrex tube 92 cm long and 2.54 cm in diameter, fitted with a flat window at Brewster's angle at each end. The reaction gases were handled in a greaseless vacuum line equipped with Teflon stopcocks, O-ring joints, oil diffusion pump, and a mechanical pump. This system was capable of evacuating the cell to a pressure of about  $10^{-5}$  Torr. Gas pressures were measured with a calibrated capacitance manometer (MKS-Baratron) in the range of 0-1000 Torr.

The B-X system of  $I_2$  was excited with the output from a CW dye laser (Spectra-Physics Model 580A) pumped by an  $Ar^+$  laser (Control Model 554A) operating at 6 W using all lines. The output of the dye laser was  $\approx 600$  mW measured with a calibrated power meter (Coherent Model 210). Selection of a strong  $I_2$  absorption line in the high-gain region of the rhodamine-6G laser was accomplished by inserting a small cell filled with iodine vapor into the laser beam and tuning the laser by moving the tuning wedge (Figure 1) until a fluorescence maximum was reached. A line with maximum absorption at 6040  $\pm 2$  Å, measured with a Bausch and Lomb 0.25-m double monochromator, was used in this study. It is known that the B-X system of  $I_2$  exhibits many closely spaced vibrational-rotational lines belonging to differential vibrational bands ( $v'$ ,  $v''$ ); therefore, many lines will be excited within the bandwidth of the dye laser at the selected wavelength. The (7,0) band of the  $I_2$  (B-X) system strongly overlaps with the laser at this wavelength.<sup>10</sup> Our goal was to study the kinetics of the laser-excited reaction of a wavelength or group of wavelengths where there is no atom production. The absorption band at 6040 Å fills this requirement<sup>9</sup> and therefore no attempt was made to identify a particular vibration-rotation line with strong absorption.

Fluorescence techniques are generally preferred over absorption techniques for detecting small changes in the concentration of a species if monitoring in the visible region.<sup>12</sup> Light scattering as well as quenching of the  $I_2$  fluorescence by  $C_2H_2$  and  $C_2H_2I_2$  prevents the use of fluorescence monitoring in this case.

Absorption measurements were made in the following way. The output from the dye laser was chopped at 50 Hz before entering the reaction cell. A portion of the input and output beams from the cell was split off by beam splitters and sent to two photodiodes (Figure 1). The output of each of these photodiodes was sent to a separate lock-in amplifier whose analog output was in turn sent to a PDP11/10 minicomputer where the normalized absorption was recorded. The computer was also used to provide an  $x$ - $y$  plot of absorbance vs. time.

In all the experiments, 0.15-0.22 Torr of  $I_2$  vapor was metered into

<sup>†</sup> Address correspondence to the author at 127 Stadler Hall, 8001 Natural Bridge Road, St. Louis, Mo. 63121.

the evacuated reaction cell followed by the addition of 45–200 Torr of acetylene. After the gases were allowed to mix for 10–20 min the laser beam was allowed to pass through the cell. All of the experiments were done in the absence of room light and at a room temperature of  $22 \pm 2$  °C.

The iodine used in the experiment was from Fisher Scientific Co. with a stated purity of 99.99%, the main impurities being  $Cl_2$  and  $Br_2$  (0.002%) and nonvolatiles (0.008%), and was used without further purification. The acetylene was drawn directly from a commercial cylinder and was purified by trap-to-trap distillation.

## Results and Discussion

When a mixture of  $I_2$  (~10 mg) and  $C_2H_2$  (~100 Torr) was irradiated for about 2 h either with  $Ar^+$  laser lines or with dye laser at  $\approx 6000$  Å, it was possible to see the needle-shaped, white crystal formation of 1,2-diiodoethylene on the inner surface of the reaction vessel. The product formation was confirmed by infrared and GC-MS analysis of the laser-exposed mixture of  $I_2 + C_2H_2$ . When the 5145- and the 4880-Å lines of the  $Ar^+$  laser, which fall below and above the dissociation limit of the B state of the  $I_2$  molecule, respectively, were used separately to expose the same concentration of  $I_2 + C_2H_2$  for the same period of time and the sample was analyzed with GC, another peak was observed which was many times weaker and had a retention time longer than that of 1,2-diiodoethylene. The intensity of this peak was higher at 4880 Å than at 5145 Å, which correlated with the excited-state iodine atom production at these two wavelengths<sup>9</sup> within experimental uncertainty. This peak was found to be due to  $C_2H_2I_4$ , probably due to the reaction of  $C_2H_2I_2$  and iodine atoms. A high-resolution gas-chromatographic analysis of such a laser-exposed sample showed the formation of the two isomers of 1,2-diiodoethylene.<sup>11</sup> A detailed study of the cis-trans isomerization of this molecule in a laser-induced chemical reaction of  $I_2 + C_2H_2$  will be published elsewhere.

When a mixture of a few milligrams (~20 mg) of  $I_2$  and a few torr of  $C_2H_2$  (~100 Torr) was heated at ~100–200 °C for about 2 h and the products were analyzed using the mass spectrometer, many high-order hydrocarbons and iodides were observed in addition to a small amount of  $C_2H_2I_2$ . These hydrocarbons and iodides were found to be dependent upon the temperature, pressure of  $C_2H_2$ , and the amount of  $I_2$  in the mixture. In a laser-induced chemical reaction of  $I_2 + C_2H_2$ , a large number of  $C_2H_2I_2$  was found with no trace of any high-order hydrocarbon as was observed in the thermal reaction. This observation indicates that the laser-induced chemical reaction of  $I_2 + C_2H_2$  is nonthermal.

In the absence of quenching rate data of  $I_2^*$  by  $C_2H_2$ , it is not possible to give detailed kinetic information on the reaction of  $I_2^* + C_2H_2$ . The mechanism of excitation and deactivation of  $I_2^*$  by the collision partners present in the system may be described as follows:

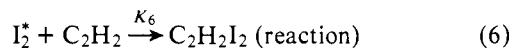
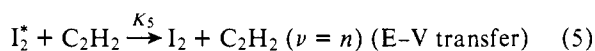
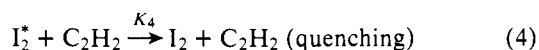
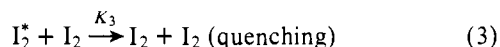
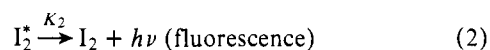

where (E-V) denotes the electronic to vibrational energy transfer from  $I_2^*$  to  $C_2H_2$ . The collisional cross section of

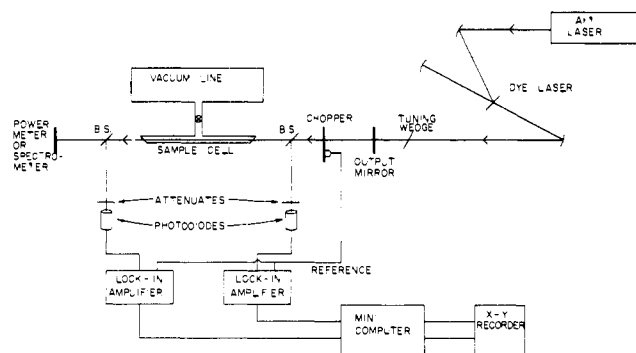
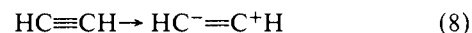

Figure 1. Experimental arrangement used in the present study (see text for details).

transfers from  $I_2^*$  by  $I_2$  is about  $69 \text{ \AA}^2$  and thus only a few collisions are required to deactivate the electronically excited  $I_2$  by the ground-state  $I_2$  molecules.<sup>13</sup> An explanation for such an efficient quenching is the electronic to electronic or vibrational energy transfer to the unexcited or excited  $I_2$  molecules. This is not very surprising, as such phenomena i.e., vibration-rotation transfer bands, have been observed in  $I_2$  in the presence of some foreign gases involving these energy-transfer processes.<sup>14,15</sup> The most interesting observation in these processes<sup>14,15</sup> was the appearance of the vibrational bands which require more energy than was available during the excitation of  $I_2$ . The probability of such events is low and is due to a collisional photoexcitation mechanism.<sup>14</sup> We believe that all these phenomena will occur from  $I_2^*$  in the presence of  $C_2H_2$  if the energy transfer to  $C_2H_2$  is slower than the collisional energy transfer to  $I_2$  molecules. The reaction mechanism of  $I_2^*$  with  $C_2H_2$  seems to be complicated. It may be explained by assuming the ionic character of  $I_2^*$  in the excited state<sup>16</sup> and may be written as follows:



The ion  $I^+$  is believed to be very reactive because of its partially filled shell and therefore it will react with the negatively charged ion,  $HC^{\ominus}=C^{\oplus}H$ , forming a positively charged ion,  $HCI=C^{\oplus}H$ , which will then react with the  $I^-$  and form a neutral molecule,  $C_2H_2I_2$ . The possibility of reactions involving the vibrationally excited species such as  $I_2(\nu = n) + C_2H_2(\nu = 0)$  and  $I_2(\nu = 0) + C_2H_2(\nu = n)$  may not be excluded.

On the basis of the laser power (200–300 mW) and the iodine pressure (0.15–0.20 Torr), the number of the excited molecules was calculated to be very low in comparison to the number of  $C_2H_2$  molecules ( $14.4 \times 10^{17}$  to  $6.4 \times 10^{18}$ ). For a system with  $[I_2^*] \ll [C_2H_2]$  and  $[I_2]$ , the reaction rate law may be assumed to follow a pseudo-first-order kinetics. In Figure 2 is shown the decay in the concentration of  $I_2$  during the reaction of  $I_2^*$  with  $C_2H_2$  on a linear as well as on a logarithmic scale. It is clear from Figure 2B that there is a small deviation in the linearity of the reaction rate curve and it becomes significant after about 2.5 h. A possible explanation<sup>17</sup> of this deviation may be given by assuming that the excitation source is a train of pulses of infinitely short duration and relating the amount of  $I_2$  consumed during reaction and other competitive processes.

$$[I_2] = [I_2]_0 - [C_2H_2I_2] \quad (9)$$

$$[I_2] = [I_2]_0 - K_6 \sum_j T_j [I_2^*]_j \quad (10)$$

$$[I_2] = [I_2]_0 - K_6 f \sum_j T_j [I_2]_j \quad (11)$$

where  $[I_2]_0$  is the concentration of  $I_2$  before the exposure of

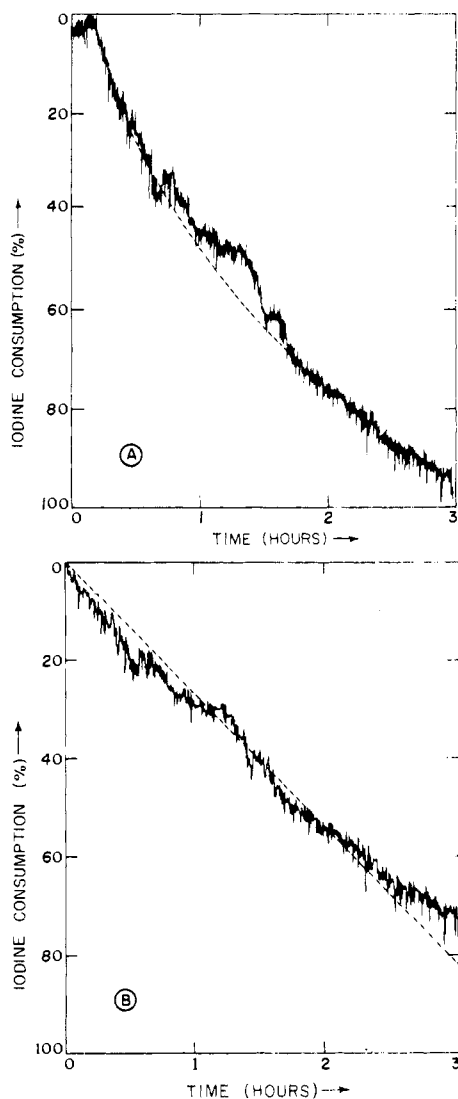

**Figure 2.** Variation in iodine concentration vs. time during the reaction of the excited iodine molecules with  $C_2H_2$ ;  $I_2 = 0.19$  Torr,  $C_2H_2 = 53.0$  Torr, laser line =  $6040 \pm 2$  Å, laser power  $\approx 100$  mW. (A) Linear plot. (B) Semilogarithmic plot.

light,  $[I_2]$  is the concentration of  $I_2$  after the exposure of light,  $T_j^{-1} = K_2 + K_3[I_2]_j + (K_4 + K_5 + K_6)[C_2H_2]$ ,  $[I_2^*]_j$  = instantaneous concentration of  $I_2^*$  formed by the  $j$ th pulse of light, and  $f$  is the fraction of photons absorbed per pulse. Now  $[I_2]_j$  will decrease roughly exponentially with increasing  $j$  (or the reaction time), so that  $[I_2]$  will decay with complicated kinetics determined by the sum of many exponentials. This apparently explains the small deviation from linearity evident in Figure 2B.

It is worth noting here that Letokhov et al.<sup>6</sup> have studied a similar reaction system involving the excited  $I_2 + 2$ -hexane and have claimed that this system could be used for a selective isotope separation of  $^{129}I_2$ . It is interesting to note that the two laser lines, i.e., the 4880 and the 5145 Å of  $Ar^+$  laser, produce excited and ground-state iodine atoms.<sup>9</sup> When these two wavelengths were used to excite  $I_2$  in a mixture of  $I_2 + 2$ -hexane, no change was observed in the iodine concentration at 4880 Å whereas product formation was observed at 5145 Å.

Under identical conditions, when a dye laser line around 5900 Å was used to excite the  $I_2$  molecules in the presence of 2-hexene, no change was found in the iodine concentration. These observations do not explain the mechanism involved in the reaction of excited  $I_2 + 2$ -hexane. Since, if the reaction mechanism involves the excited  $I_2$  molecules, the product formation is expected to be observed around 5900 Å, as the probability of molecular  $I_2$  excitation is good in this wavelength region and there is no atom production,<sup>9</sup> and if it involves the excited iodine atoms, product formation should have been about five times more at 4880 Å than at 5145 Å. The probability of atom production is about five times more at 4880 Å than at 5145 Å. If the reaction is occurring only at 5145 Å, it cannot be used for a selective isotope separation of  $^{129}I_2$ . The line at 5145 Å produces about 18% of the excited iodine atoms in the  $^2P_{1/2}$  state and therefore the isotope selectivity will be destroyed due to atomic chain reaction. The excitation of  $I_2$  at  $6040 \pm 2$  Å does not produce excited iodine atoms<sup>9</sup> and the molecule  $C_2H_2$  is very reactive with the excited  $I_2$  molecules and therefore the reaction scheme involving excited  $I_2$  and the  $C_2H_2$  seems to be an attractive one for a selective laser isotope separation of  $^{129}I_2$ . Experiments are underway in this direction in our laboratory and the results will be published elsewhere.

**Acknowledgments.** This work was supported by the U.S. Department of Energy, Division of Basic Energy Sciences, through Contract No. W-7405-Eng-82. We wish to thank Mr. L. E. Steenhoek for technical assistance.

#### References and Notes

- (1) (a) V. S. Letokhov, C. B. Moore, and R. V. Ambartzumian, "Chemical and Biological Applications of Lasers", Vol. 3, C. B. Moore, Ed., Academic Press, New York, 1977; (b) N. G. Basov, ref 1a, Vol. 1, 1974.
- (2) (a) N. Bloembergen and E. Yablonovitch, *Phys. Today*, 23 (1978), and references cited therein; (b) J. Wolfrum, *Ber. Bunsenges Phys. Chem.*, **81**, 125 (1977); (c) R. V. Ambartzumian, N. V. Chekalin, V. S. Letokhov, and E. A. Ryabov, *Chem. Phys. Lett.*, **36**, 301 (1975); (d) A. Hartford, Jr., *ibid.*, **57**, 352 (1978); (e) J. C. Stephenson and S. M. Freund, *J. Chem. Phys.*, **65**, 4303 (1976); *Chem. Phys. Lett.*, **41**, 157 (1976).
- (3) (a) S. Datta, R. W. Anderson, and R. N. Zare, *J. Chem. Phys.*, **63**, 5503 (1975); (b) D. D. S. Liu, S. Datta, and R. N. Zare, *J. Am. Chem. Soc.*, **97**, 2557 (1975); (c) D. M. Brenner, S. Datta, and R. N. Zare, *ibid.*, **99**, 4554 (1977).
- (4) M. Stuke and F. P. Safer, *Chem. Phys. Lett.*, **48**, 271 (1977).
- (5) S. J. Harris, *J. Am. Chem. Soc.*, **99**, 5798 (1977).
- (6) (a) V. I. Balykin, V. S. Letokhov, V. I. Mishin, and V. A. Semchishen, *Chem. Phys.*, **17**, 111 (1976); (b) V. S. Letokhov and V. A. Semchishen, *Spectrosc. Lett.*, **8**, 263 (1975); *Sov. Phys. Dokl.*, **20**, 423 (1975).
- (7) V. S. Kushawaha, to be submitted for publication.
- (8) APS Study Group on Nuclear Fuel Cycles and Waste Management, *Rev. Mod. Phys.*, **50**, 1 (1978).
- (9) (a) T. W. Broadbent and A. B. Callear, *J. Chem. Soc., Faraday Trans. 2*, **68**, 1367 (1972); (b) D. H. Burde, R. A. McFarlane, and J. R. Wiesenfeld, *Phys. Rev. A*, **10**, 1917 (1974).
- (10) K. Sakurai and H. P. Broida, *J. Chem. Phys.*, **54**, 1220 (1971).
- (11) The 1,2-diiodoethylene was prepared by passing acetylene through a solution of  $I_2 + 95\%$  alcohol (R. M. Noyes, R. G. Dickinson, and V. Schomaker, *J. Am. Chem. Soc.*, **67**, 1319 (1945)). This reaction is very slow. A gas-chromatographic analysis of the purified compound showed formation of only the trans isomer of 1,2-diiodoethylene. The laser-induced reaction is comparatively very fast and produces both the cis and trans isomers of this compound.
- (12) J. I. Steinfeld and P. L. Huston, "Laser and Coherence Spectroscopy", J. I. Steinfeld, Ed., Plenum Press, New York, 1978.
- (13) G. A. Capelle and H. P. Broida, *J. Chem. Phys.*, **58**, 4212 (1973).
- (14) C. Arnot and C. A. McDowell, *Can. J. Chem.*, **36**, 114 (1958).
- (15) J. I. Steinfeld, "Molecular Spectroscopy: Modern Researches", K. N. Rao, Ed., Academic Press, New York, 1972.
- (16) (a) W. K. Duerksen and M. Tamres, *J. Am. Chem. Soc.*, **90**, 1379 (1968); (b) H. A. Bensoi and J. H. Hildebrand, *ibid.*, **71**, 2703 (1949); (c) G. A. Russel, *ibid.*, **80**, 4987 (1958); (d) F. E. Cummings and W. Klemperer, *J. Chem. Phys.*, **60**, 2035 (1974).
- (17) The author thanks the referee of this manuscript for the valuable suggestions.